

Position of Parts in Instrument Panel <LHD>

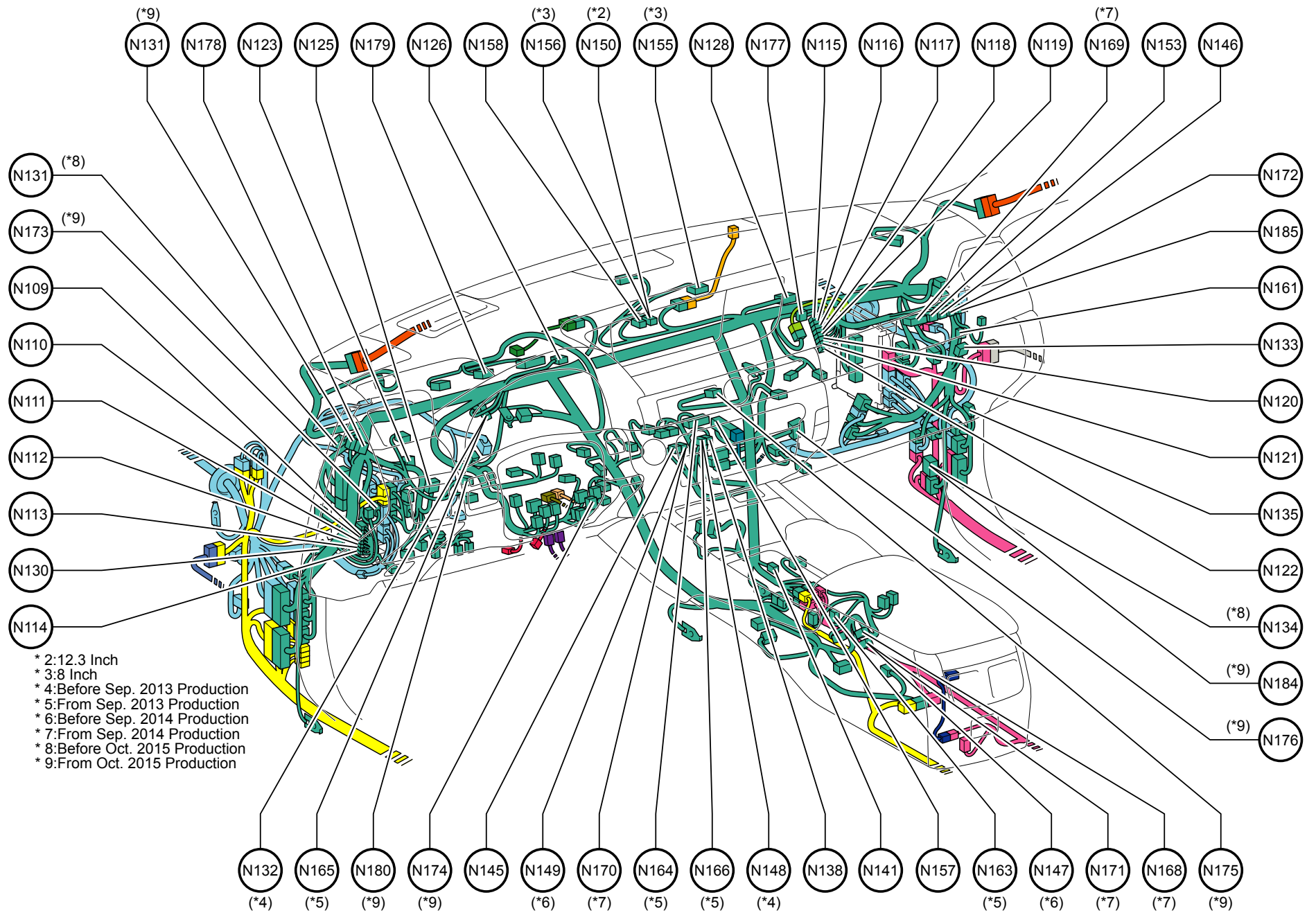

N 109 Junction Connector  
N 110 Junction Connector  
N 111 Junction Connector  
N 112 Junction Connector  
N 113 Junction Connector  
N 114 Junction Connector  
N 115 Junction Connector  
N 116 Junction Connector  
N 117 Junction Connector  
N 118 Junction Connector  
N 119 Junction Connector  
N 120 Junction Connector  
N 121 Junction Connector  
N 122 Junction Connector  
N 123 Junction Connector  
N 125 Junction Connector  
N 126 Junction Connector  
N 128 Junction Connector  
N 130 Junction Connector  
N 131 Junction Connector  
N 132 Junction Connector  
N 133 Junction Connector  
N 134 Junction Connector  
N 135 Junction Terminal  
N 138 Multi-Media Module Receiver Assembly  
N 141 No. 2 Antenna Cord Sub-Assembly  
N 145 Multi-Media Module Receiver Assembly  
N 146 Telematics Transceiver  
N 147 Stereo Jack Adapter Assembly  
N 148 Multi-Media Module Receiver Assembly  
N 149 Multi-Media Module Receiver Assembly  
N 150 Accessory Meter Assembly  
N 153 Telematics Transceiver  
N 155 Multi-Display  
N 156 Multi-Display  
N 157 A/C Amplifier Assembly  
N 158 Accessory Meter Assembly  
N 161 Junction Connector  
N 163 Shift Position Indicator  
N 164 Multi-Media Module Receiver Assembly  
N 165 Junction Connector  
N 166 Multi-Media Module Receiver Assembly  
N 168 Stereo Jack Adapter Assembly  
N 169 Telematics Transceiver  
N 170 Multi-Media Module Receiver Assembly  
N 171 Stereo Jack Adapter Assembly  
N 172 Telematics Transceiver  
N 173 Driving Support ECU Assembly  
N 174 Spiral Cable Sub-Assembly  
N 175 Clock Assembly  
N 176 Network Gateway ECU  
N 177 Junction Connector  
N 178 Junction Connector  
N 179 Combination Meter Assembly  
N 180 Trip Switch  
N 184 Junction Connector  
N 185 Telematics Transceiver

Position of Parts in Instrument Panel <LHD>

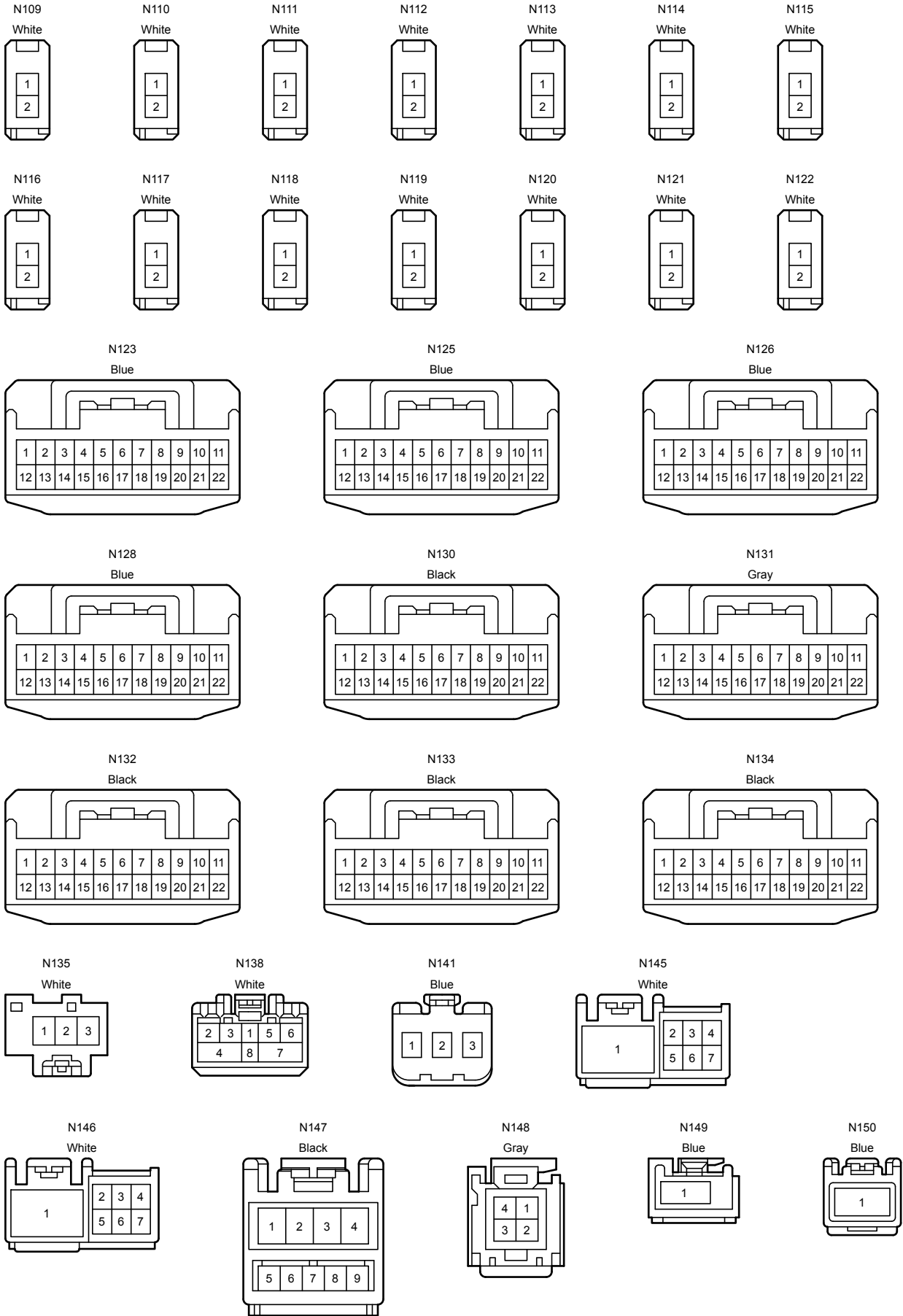

Position of Parts in Instrument Panel <LHD>

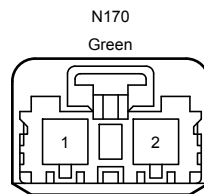
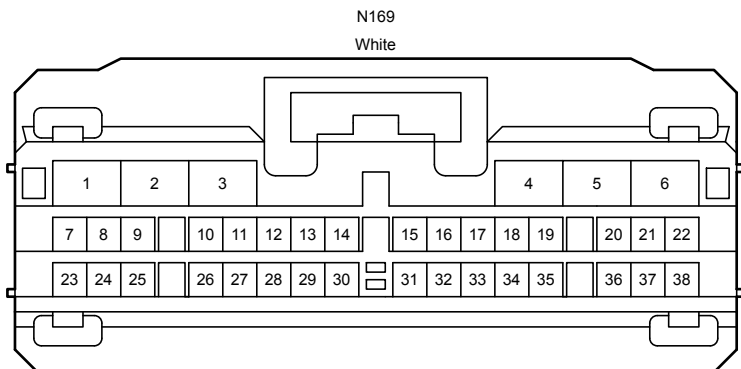
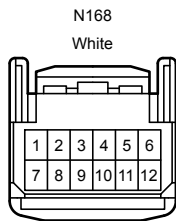
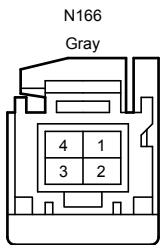
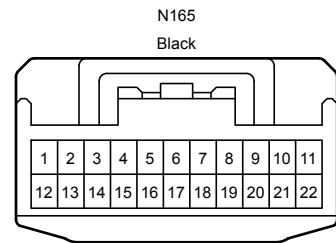
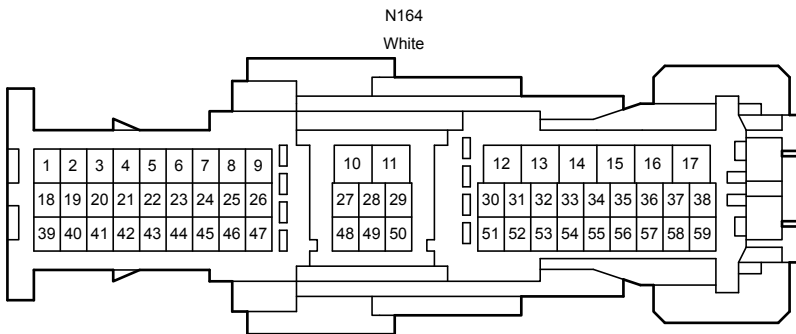
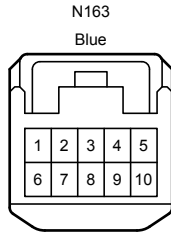
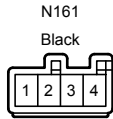
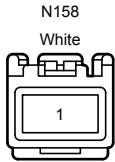
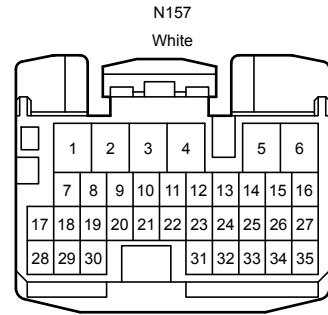
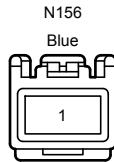
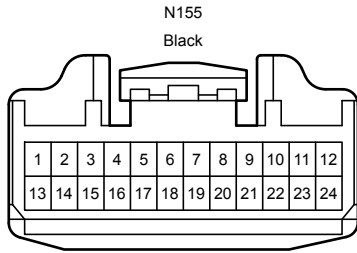
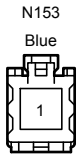

Position of Parts in Instrument Panel <LHD>

