

F RELAY LOCATIONS

[Engine Room R/B Assembly No. 1 and Engine Room J/B Assembly No. 1 Inner Circuit]

- * 1:80A RH J/B DC/DC (Before Oct. 2015 Production)
80A LUG J/B DC/DC (From Oct. 2015 Production)
- * 2:2AR-FSE
- * 3:2GR-FXE From Oct. 2015 Production

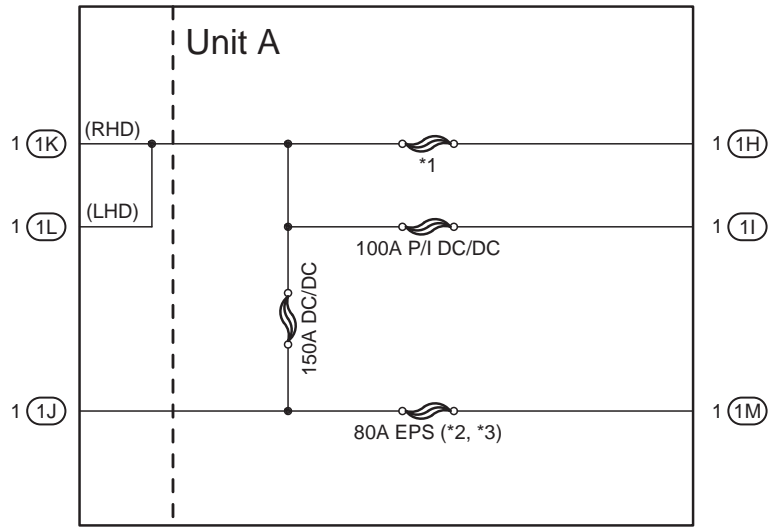

Unit B

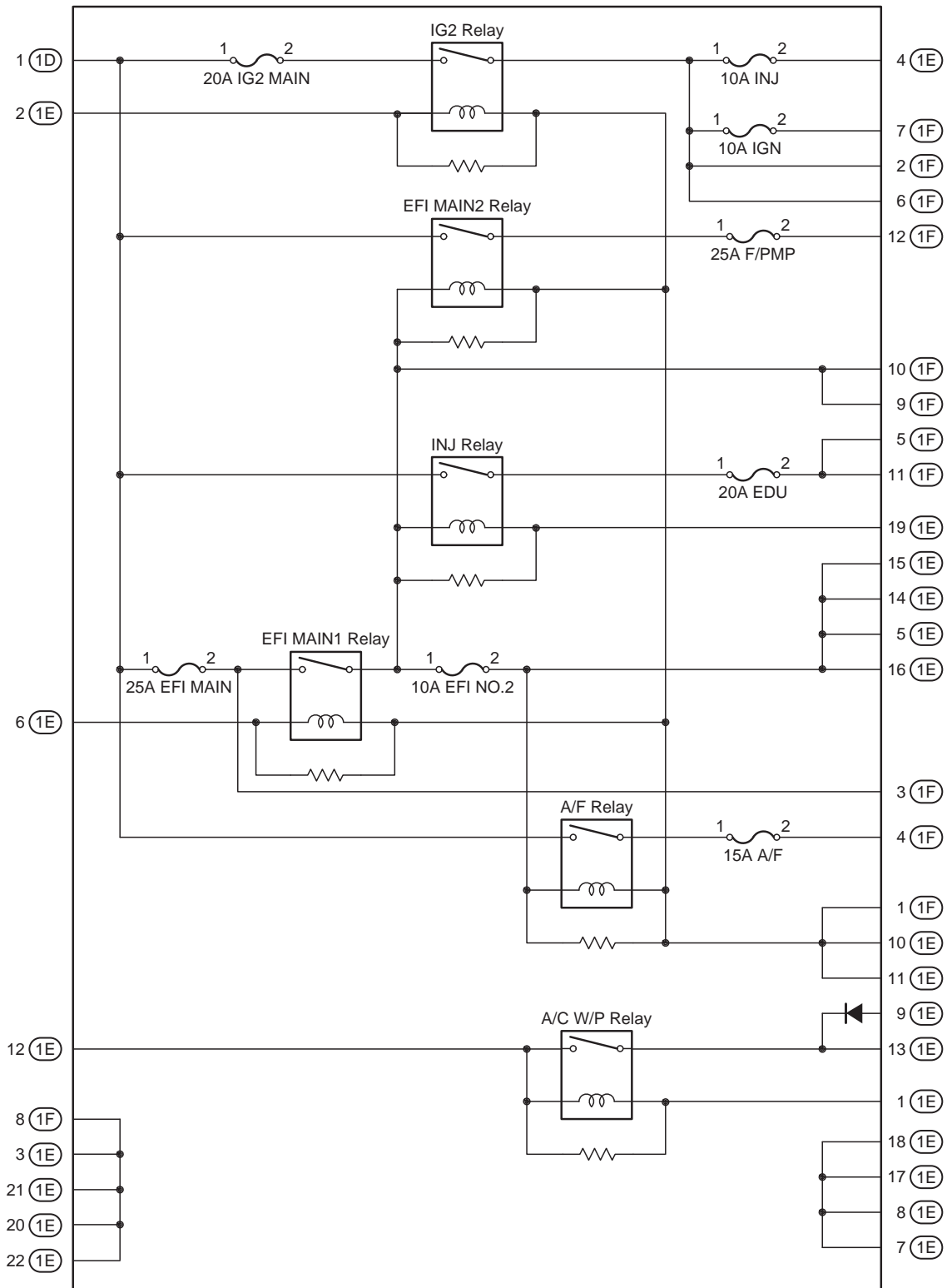

F RELAY LOCATIONS

[Engine Room R/B Assembly No. 1 and Engine Room J/B Assembly No. 1 Inner Circuit]

Unit C

