

F RELAY LOCATIONS

[Cowl Side J/B LH Inner Circuit]

* 1: Before Oct. 2015 Production * 3: 15A HAZ (*1) * 4: 10A CAPACITOR(HV) (*1)
 * 2: From Oct. 2015 Production 10A HAZ (*2) 7.5A LH J/B-B (*2)

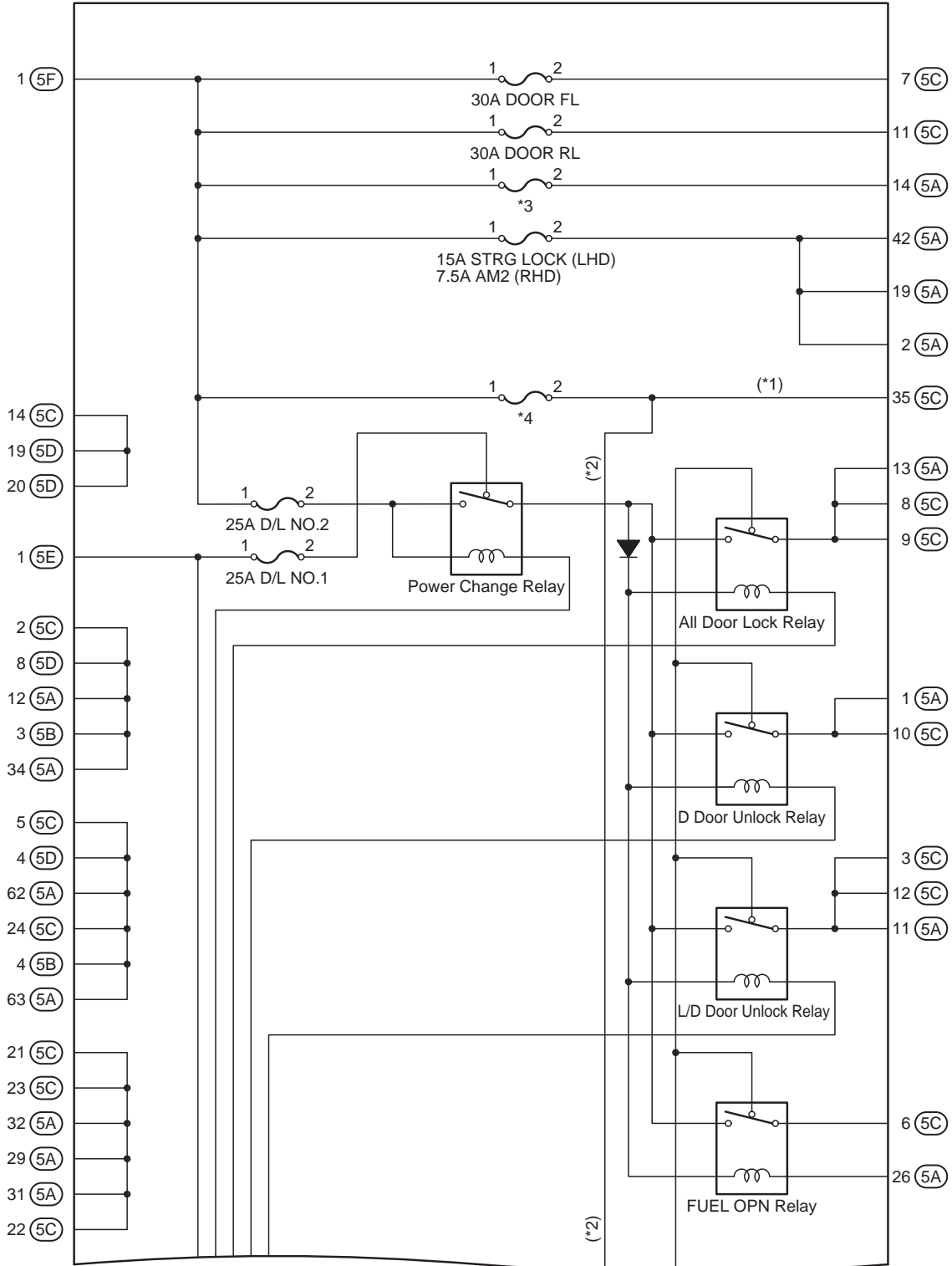

(Cont. Next Page)

* 1: Before Oct. 2015 Production
 * 2: From Oct. 2015 Production

(Cont'd)

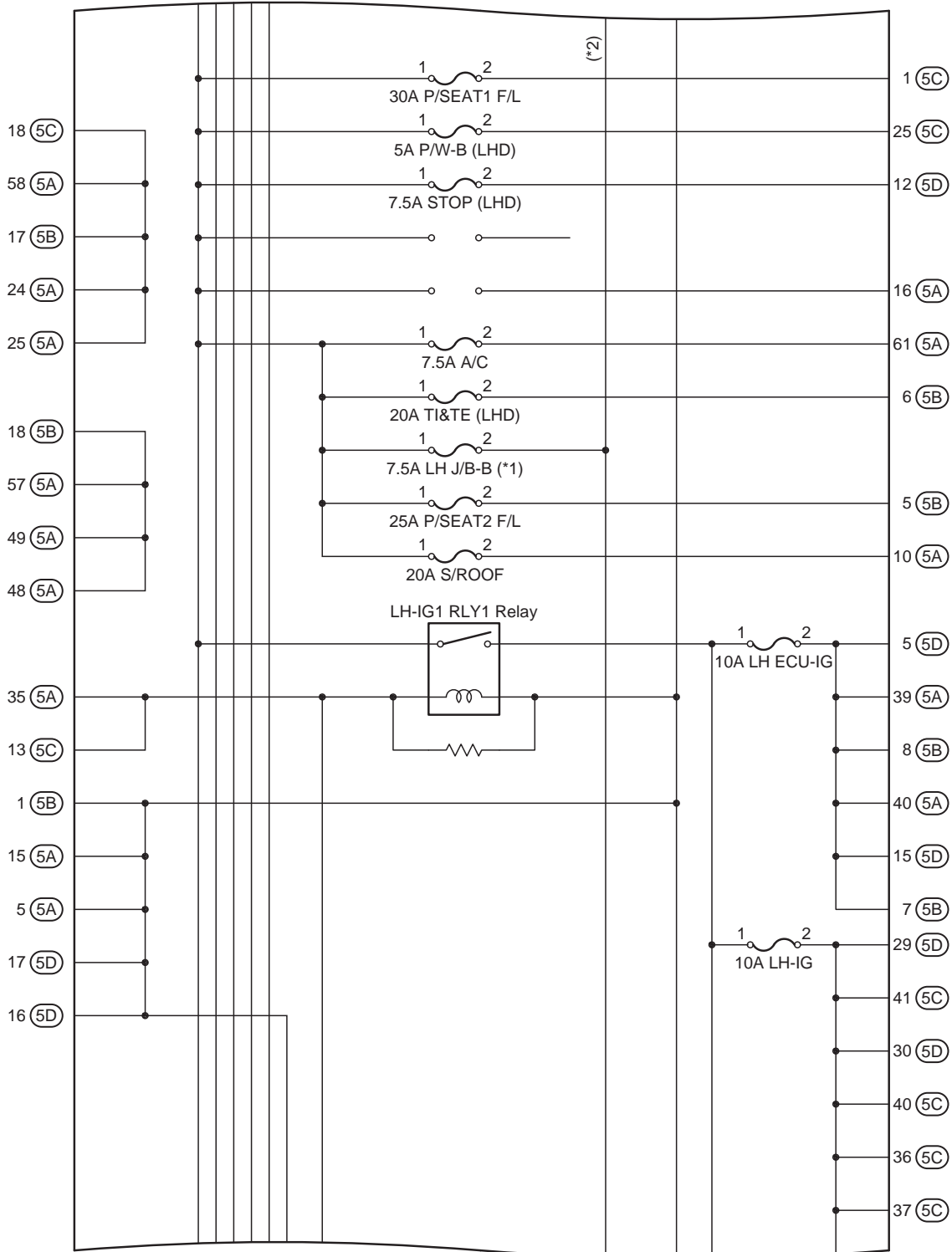

(Cont. Next Page)

F RELAY LOCATIONS

[Cowl Side J/B LH Inner Circuit]

* 1: Before Oct. 2015 Production * 5: 10A NV-IR (*1)
 * 2: From Oct. 2015 Production 5A LH ECU-IG NO.2 (*2)

(Cont'd)

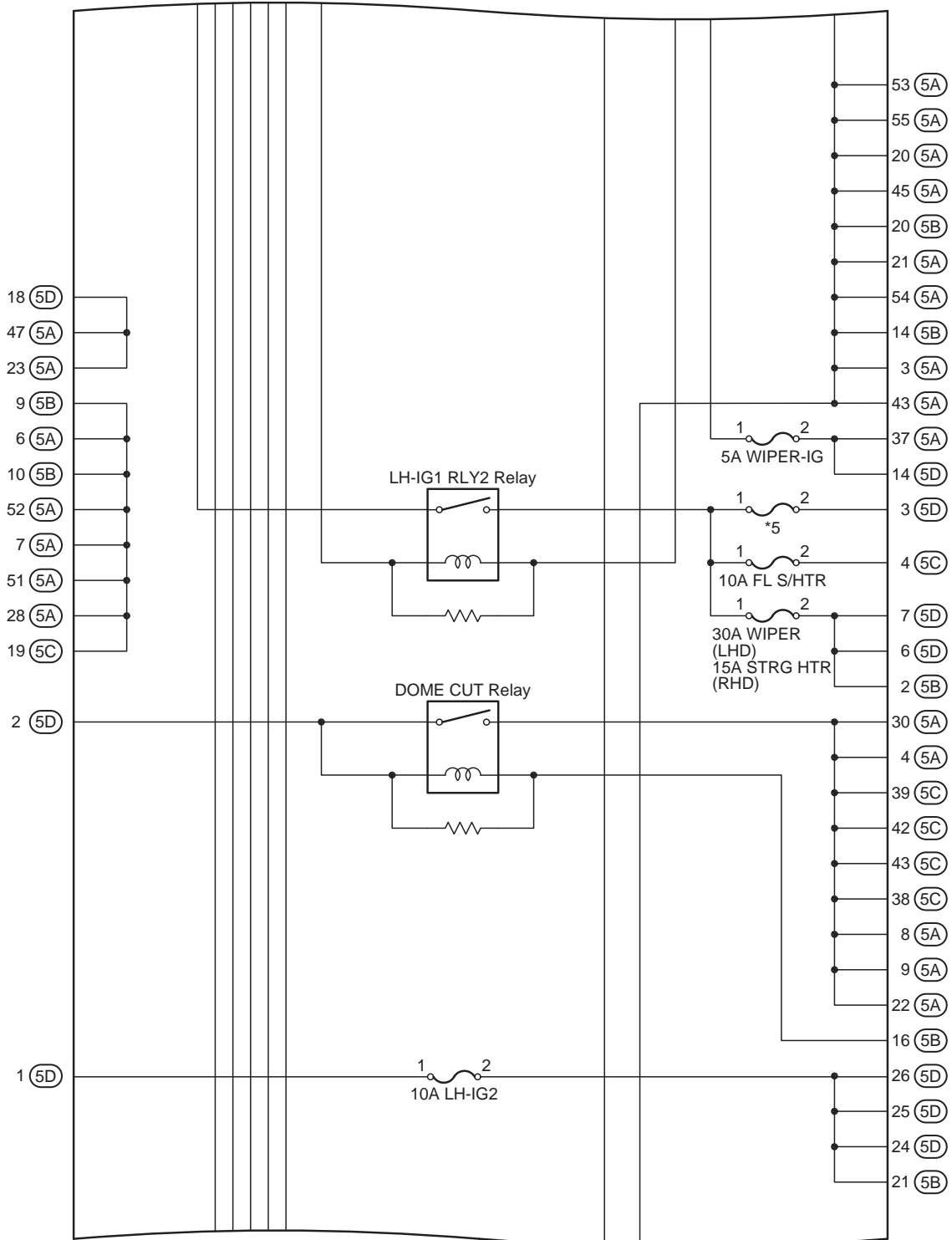

(Cont. Next Page)

(Cont'd)

